



## FEATURES

- Atom N270 1.6Hz/ D525 1.8Hz Low-power Processor
- 1GB DDR2 533MHz SDRAM
- USB 2.0 x 4, PS2 x 2, VGA x 1
- DB-9 For RS232 x 6, DB-25 x 1
- 10/100/1000Base, RJ 45 x 2
- 12V DC\_Input
- Support Windows XP, Windows 7, Linux

## SPECIFICATIONS

SYSTEM	
Processor	Atom N270 1.6Hz/ D525 1.8Hz Low-power Processor
System Memory	1GB DDR2 533MHz SDRAM
Ethernet	10/100/1000Base, RJ 45 x 2
I/O Port	USB 2.0 x 4 DB-9 For RS232 x 6 DB-25 x 1 Audio x 1 Power Input x 1 VGA x 1 PS2 x 2
Storage Disk Drive	Support SATA 2.5"SSD, HDD And DOM Card
Expansion Slot	-
Operating System Support	Windows XP, Windows 7, Linux

### LCD

Display Type	17"VGA TFT LED Backlight
Max Resolution	1280x1024
Max. Colors	16M
Luminance	350cd/m2
Viewing Angle	160°(H), 160°(V)
Back Light MTBF (Hours)	50000

### TOUCH SCREEN

Type	Heat 5 wire analog resistive
Light Transmission	More Than 81%
Life Time	35 Million Times Click

### POWER SUPPLY

DC Input	DC_IN 12V
----------	-----------

### ENVIRONMENTAL

Operating Temperature	0°C ~ 60°C
Storage Temperature	-20°C ~ 70°C
Storage Humidity	10%~ 95%@40°C Relative Humidity, Non-condensing

## MECHANICAL

Construction	The Panel Is Made Of Aluminum-magnesium Alloy, And The Whole Surface Of The Shell Is Processed By Aluminum-magnesium Alloy
Mounting	VESA / Panel Embedded Mount
Dimensions	425X337X79mm
Weight	4.0KG

## DIMENSION ( Unit: mm )

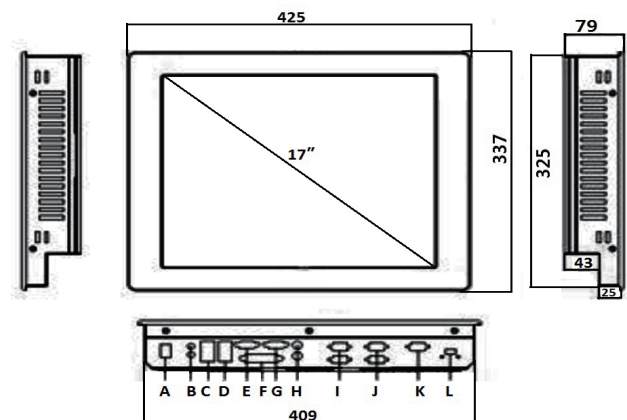

A-----ON/OFF    E-----VGA    I-----COM2/3  
 B-----Audio    F-----DB-25    J-----COM4/5  
 C-----USB/RJ45    G-----COM1    K-----COM6  
 D-----USB/RJ45    H-----PS2    L-----Power Input

The Hole Size : 411X327mm